



POWER

RMS 600_w

MAX 1200_w

MAD S3-12D2

LIGHT WEIGHT WITH HEAVY BASS

The MAD S3-12.D2 subwoofer is a game changer! Similar to the MAX S1/S2 series, this subwoofer has been loaded with a light-weight non-pressed paper cone and a 3D aluminum dust cap to hit hard, play LOUD and endure the toughest beats. The aluminum dust cap transfers away heat from the voice coils, and the embossed GAS logo mini- mizes resonances and ensures stability in every beat.

STRONG AND FLEXIBLE

Borrowing from the MAX S1/S2 series, we've equipped the MAD S3-12.D2 with a rubber suspension featuring dual- stitching. The suspension is strong, resilient and flexible to create a powerful sound that will shock and amaze! Of course, the dual-stitching comes in the iconic GAS orange that we all madly love.

HARDCORE MADNESS

The heart of the MAD S3 subwoofers is in the fully stacked core.

First: Dual 2-Ohm 2" TIL voice coils with 4-layer copper wire. This MAD setup creates allot of bass that's not only deep, but fast and hard hitting too! The voice coils are "non-conductive", which means they move smoothly through the magnetic gap without missing a beat.

Second: We have combined the MAD S1/S2 series robust steel M-basket with a double- stacked HQ ferrite motor from the MAX S1 series to create a real powerhouse! We've also included a robust pressure-bonded M-gasket in IMPP material that stabilizes the basket and minimizes the risk of damaging the suspension when securing the subwoofer.

STAY COOL, STAY LOUD

To make sure that the MAD S3 subwoofer stays cool, we have taken our popular DVS™ ventilation system to a new level. With the improved DVS2™ ventilation system (same technology that is used in the popular MAX S1 series) placed in both the subwoofer's backplate and in the basket under the spider, the MAD S3 series will keeps things cool even when the beats are scorching.

SPECIFICATIONS

MAD S3-12D2	
Component	Subwoofer
Size	12" (300 mm)
Nominal Impedance	2+2 Ohm
Power RMS	600 W
Power MAX	1200 W
Freq. response	20-200 Hz
Voice Coil	Dual 2" 4-layer copper wire
Cone	NPP
Dustcap	3D aluminum
Basket	M Steel
Magnet	2x52 oz HQ Ferrite
Suspension	Rubber with dual stitching
Weight	5.7 KG

PARAMETERS	
Impedance	2+2 Ohm
Re	3.6 Ohm
Fs	29 Hz
Qms	3.93
Qes	0.39
Qts	0.35
Vas	62.6 L
Sd	491.3 cm ²
Mms	158 g
Le	2.712 mH
Xmax	27 mm
dB/SPL	88 dB 1W/1M
Bl	16.5
Driver Vol. Displacement	2.23 L

DIMENSIONS (mm)

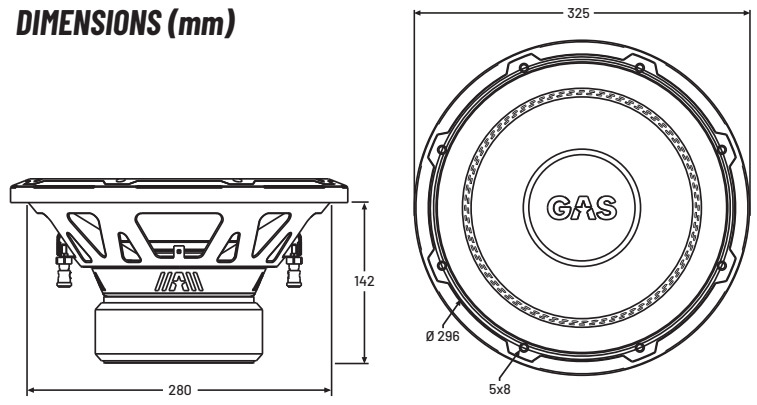

IMPEDANCE VS FREQUENCY

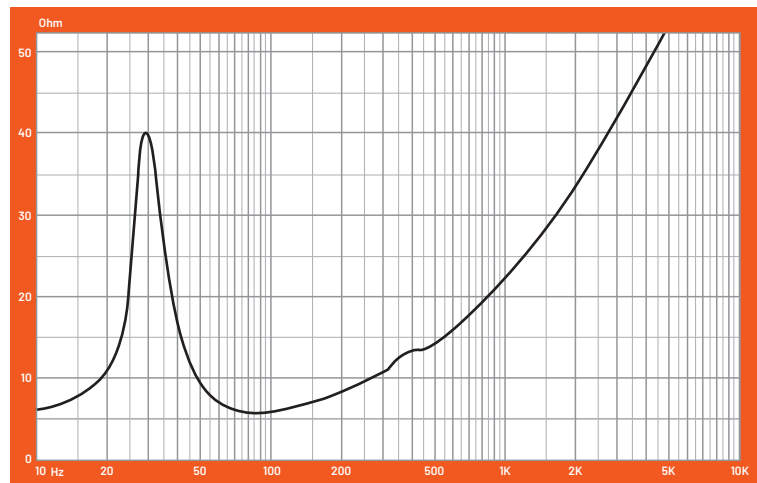

ENCLOSURE RECOMMENDATIONS

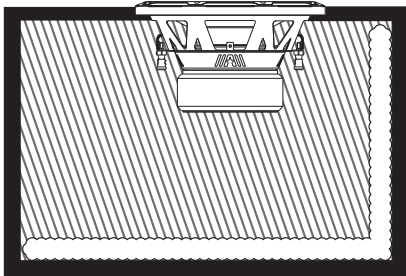

SEALED

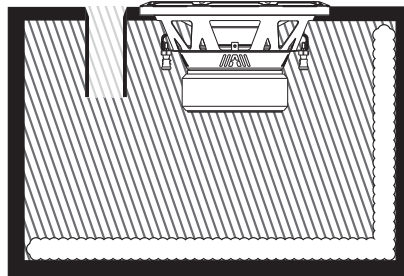

VENTED

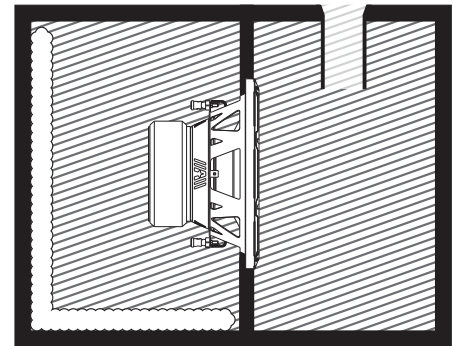

4TH ORDER BANDPASS

VENTED PERFECTION

To unleash the MADness of the MAD S3-12.D2 subwoofer, you need to mount it in an enclosure. Not just any type of enclosure – a ported enclosure! The subwoofers hardcore construction and powerful performance have been optimized for ported constructions. Your sound system will never be the same, and the definition of LOUD have been rewritten by the MAD S3 series.

MAD S3-12D2:

	TOTAL VOLUME	FB	F3	PORT SIZE Ø	PORT LENGTH	POLYFILL
VENTED	37.87L*	42Hz	39.7Hz	1x4" (10.3cm)	38.3cm	Minimal
VENTED SPL	49.22L**	45Hz	38.9Hz	1x4" (10.3cm)	20.8cm	Minimal

* Total volume = Volume Net (32L) + Volume driver (2.27L) + Volume port (3.6L)

** Total volume = Volume Net (45L) + Volume driver (2.27L) + Volume port (1.95L)

